

GRISWOLD FILTRATION

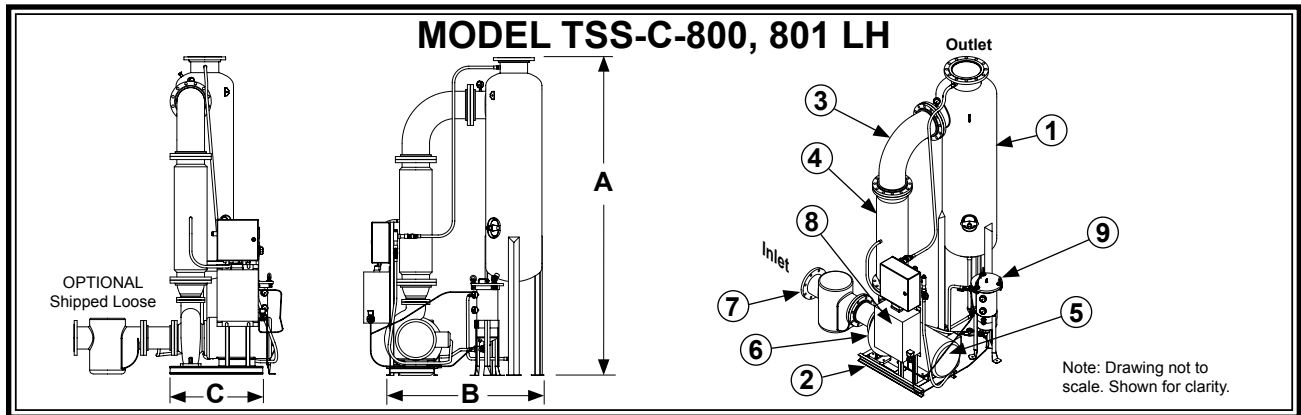

SYSTEM MODEL		TSS-C-800-LH	TSS-C-801-LH
	Design Flow Rate, GPM	1400@40 TDH	1700@40 TDH
Item 1	Separator Model	CS-8T-FLG Carbon Steel, Powder Coated	
Item 2	Frame Construction	Carbon Steel, Powder Coated	
Item 3	Pipe Assembly	Carbon Steel, Rust Inhibitor Primer with Enamel finish	
Item 4	SBC Model	SBC-8000	
MOTOR 460 VAC TEFC			
Item 5	Horsepower	20 hp	25 hp
	Approximate Amps @ 460V	27 amps	34 amps
	RPM	1750	
PUMP			
Item 6	Pump Casing	Cast Iron	
	Pump Impeller	Bronze	
	Std.Mechanical Seal	VITON Elastomer, Silicon Carbide Seat, Carbon Rotary	
BASKET STRAINER (Optional)			
Item 7	Body Construction	Cast Iron	
	Internal Screen	1/4" Perforated 304 Stainless Steel	
	Connection Type	Class 150 FLG	
CONTROL PANEL (UL listed and labeled, manufactured to UL-508A Std.)			
Item 8	Enclosure	NEMA 4 Powder Coated, Watertight, UL listed and CSA approved	
	Electrical Components	Starter with Thermal Overload, HOA, 460/120 Transformer with Circuit Breakers, Pump "RUN" Light, Lockable Door Disconnect, Magnetic Contactor, Manufactured with all UL listed & CSA approved electrical components.	
	Service Light (Standard)	25 Watt, Amber, 120 VAC	
RECOVERY TANK			
Item 9	Body Construction	304 Stainless Steel	
	Internal Screen	304 Stainless Steel	
	Filter Bag	25 Micron Polypropylene	
	Differential Press. Switch	Dial Indicator with Dry N.O. Contact	
SPECIFICATIONS			
	Dim "A"	120"	
	Dim "B"	60"	
	Dim "C"	50"	
	Max. Inlet P.S.I.	100	
	Max. Operating P.S.I.	150	
	Max. Operating Temp.	120°F	
	Inlet with or without Strainer (Class 150 FLG)	8"	
	Outlet (Class 150 FLG.)	8"	
	Shipping Weight	3005 Lbs	

Note: Dimensions are approximate and are for reference only. Dimensions subject to change without notice. Weights are approximate.