

GRISWOLD FILTRATION

MODEL TSS-C-150, 151 LH

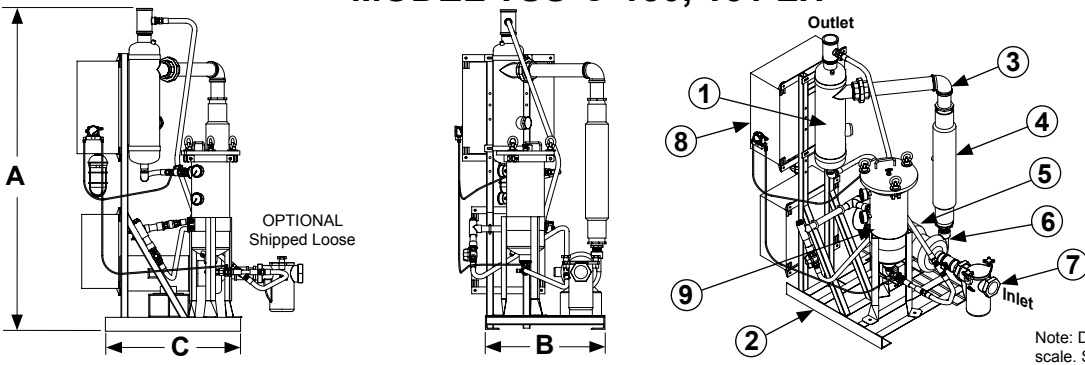

SYSTEM MODEL		TSS-C-150-LH	TSS-C-151-LH
	Design Flow Rate, GPM	54@40 TDH	68@40 TDH
Item 1	Separator Model	CS-1.5T-THD Carbon Steel, Powder Coated	
Item 2	Frame Construction	Carbon Steel, Powder Coated	
Item 3	Pipe Assembly	Schedule 80 PVC with Enamel Finish*	
Item 4	SBC Model	SBC-2000	
MOTOR 460 VAC TEFC			
Item 5	Horsepower	1-1/2 hp	
	Approximate Amps @ 460V	3 amps	
	RPM	3500	
PUMP			
Item 6	Pump Casing	Cast Iron	
	Pump Impeller	Bronze	
	Std.Mechanical Seal	VITON Elastomer, Silicon Carbide Seat, Carbon Rotary	
BASKET STRAINER (Optional)			
Item 7	Body Construction	Cast Iron	
	Internal Screen	1/4" Perforated 304 Stainless Steel	
	Connection Type	Female NPT Thread	
CONTROL PANEL (UL listed and labeled, manufactured to UL-508A Std.)			
Item 8	Enclosure	NEMA 4 Powder Coated, Watertight, UL listed and CSA approved	
	Electrical Components	Starter with Thermal Overload, HOA, 460/120 Transformer with Circuit Breakers, Pump "RUN" Light, Lockable Door Disconnect, Magnetic Contactor, Manufactured with all UL listed & CSA approved electrical components.	
	Service Light (Standard)	25 Watt, Amber, 120 VAC	
RECOVERY TANK			
Item 9	Body Construction	304 Stainless Steel	
	Internal Screen	304 Stainless Steel	
	Filter Bag	25 Micron Polypropylene	
	Differential Press. Switch	Dial Indicator with N.O. Dry Contact	
SPECIFICATIONS			
	Dim "A"	67"	
	Dim "B"	26-1/8"	
	Dim "C"	29-1/4"	
	Max. Inlet P.S.I.	100	
	Max. Operating P.S.I.	150	
	Max. Operating Temp.	100°F	
	Inlet w/out Strainer (with Strainer) (NPT Thread)	2" (2-1/2")	
	Outlet (NPT Thread)	1-1/2"	
	Shipping Weight	490 Lbs	

* Optional or as required by temperature/pressure requirements---Carbon Steel, Rust Inhibitor Primer with Enamel finish

Note: Dimensions are approximate and are for reference only. Dimensions subject to change without notice. Weights are approximate.

REV. A
08/07