

GRISWOLD FILTRATION

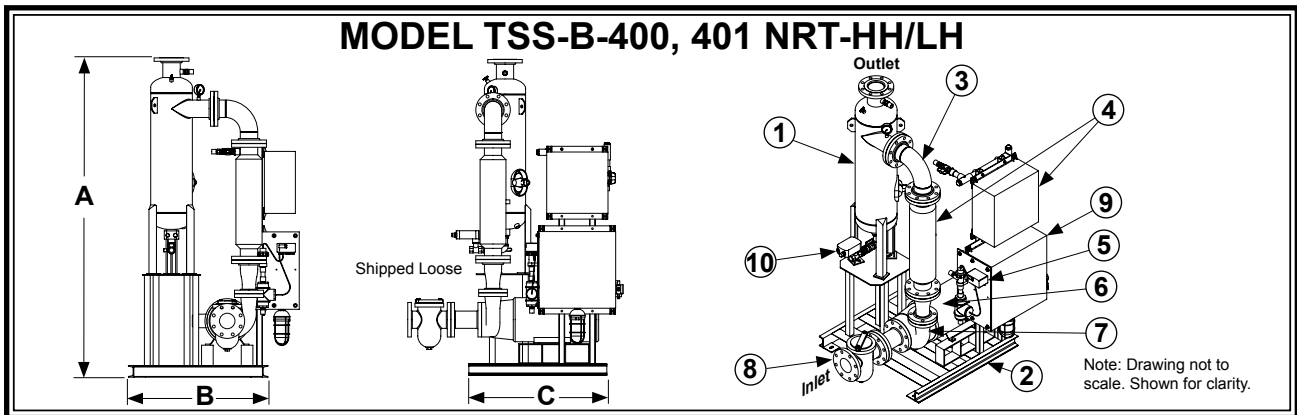

SYSTEM MODEL		TSS-B-400-NRT-HH	TSS-B-401-NRT-HH	TSS-B-400-NRT-LH	TSS-B-401-NRT-LH
	Design Flow Rate, GPM	340@80 TDH	420@80 TDH	340@40 TDH	420@40 TDH
Item 1	Separator Model	CS-4T-FLG Carbon Steel, Powder Coated			
Item 2	Frame Construction	Carbon Steel, Powder Coated			
Item 3	Pipe Assembly	Schedule 80 PVC with Enamel Finish*			
Item 4	SBC Model	SBC-4000			
Item 5	Conductivity Meter	(SEE SECTION 12)			
MOTOR 460 VAC TEFC					
Item 6	Horsepower	10 hp	15 hp	5 hp	7.5 hp
	Approximate Amps @ 460V	14 amps	21 amps	7.6 amps	11 amps
	RPM	3500			
PUMP					
Item 7	Pump Casing	Cast Iron			
	Pump Impeller	Bronze			
	Std.Mechanical Seal	VITON Elastomer, Silicon Carbide Seat, Carbon Rotary			
BASKET STRAINER (Standard)					
Item 8	Body Construction	Cast Iron			
	Internal Screen	1/4" Perforated 304 Stainless Steel			
	Connection Type	Class 150 FLG			
CONTROL PANEL (UL listed and labeled, manufactured to UL-508A Std.)					
Item 9	Enclosure	NEMA 4 Powder Coated, Watertight, UL listed and CSA approved			
	Electrical Components	Starter with Thermal Overload, HOA, 460/120 Transformer with Circuit Breakers, Pump "RUN" Light, Lockable Door Disconnect, Magnetic Contactor, Manufactured with all UL listed & CSA approved electrical components.			
	Service Light (Standard)	25 Watt, Amber, 120 VAC			
PURGE VALVE					
Item 10	Actuator, Motorized	120 VAC 60Hz			
	Connection type	1-1/2" Female NPT, Ball Valve			
SPECIFICATIONS					
	Dim "A"	83"			
	Dim "B"	36"			
	Dim "C"	36"			
	Max. Inlet P.S.I.	100			
	Max. Operating P.S.I.	150			
	Max. Operating Temp.	100°F			
	Inlet (Class 150 FLG.)	4"			
	Outlet (Class 150 FLG.)	4"			
	Shipping Weight	1004 Lbs			

Note: Dimensions are approximate and are for reference only. Dimensions subject to change without notice. Weights are approximate.
 * Optional or as required by temperature/pressure requirements---Carbon Steel, Rust Inhibitor Primer with Enamel finish