

# GRISWOLD FILTRATION

## MODEL TSS-B-300, 301 HH/LH

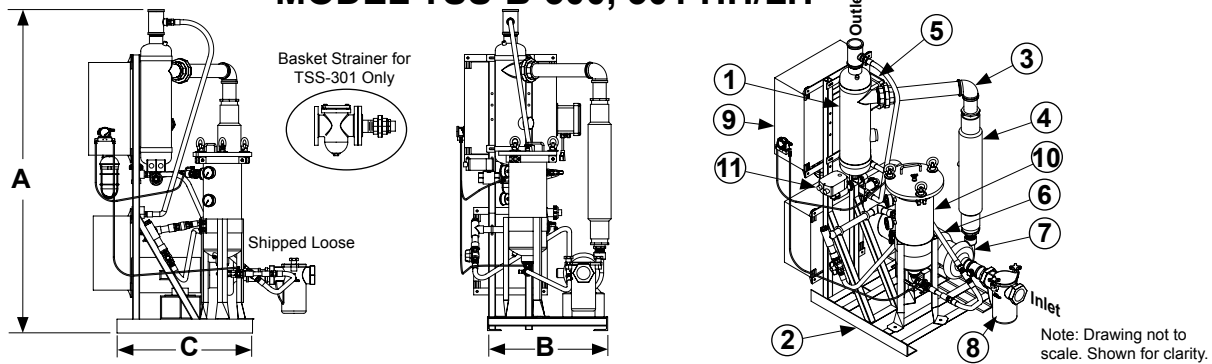

SYSTEM MODEL		TSS-B-300-HH	TSS-B-301-HH	TSS-B-300-LH	TSS-B-301-LH
	Design Flow Rate, GPM	200@80 TDH	250@80 TDH	200@40 TDH	250@40 TDH
Item 1	Separator Model	CS-3T-THD Carbon Steel, Powder Coated			
Item 2	Frame Construction	Carbon Steel, Powder Coated			
Item 3	Pipe Assembly	Schedule 80 PVC with Enamel Finish*			
Item 4	SBC Model	SBC-3000			
Item 5	Conductivity Meter	(SEE SECTION 12)			
<b>MOTOR 460 VAC TEFC</b>					
Item 6	Horsepower	7.5 hp	10 hp	3 hp	5 hp
	Approximate Amps @ 460V	11 amps	14 amps	4.8 amps	7.6 amps
	RPM	3500			
<b>PUMP</b>					
Item 7	Pump Casing	Cast Iron			
	Pump Impeller	Bronze			
	Std.Mechanical Seal	VITON Elastomer, Silicon Carbide, Carbon Rotary			
<b>BASKET STRAINER (Standard)</b>					
Item 8	Body Construction	Cast Iron			
	Internal Screen	1/4" Perforated 304 Stainless Steel			
	Connection Type	Female NPT Thread	Class 150 FLG	Female NPT Thread	Class 150 FLG
<b>CONTROL PANEL (UL listed and labeled, manufactured to UL-508A Std.)</b>					
Item 9	Enclosure	NEMA 4 Powder Coated, Watertight, UL listed and CSA approved			
	Electrical Components	Starter with Thermal Overload, HOA, 460/120 Transformer with Circuit Breakers, Pump "RUN" Light, Lockable Door Disconnect, Magnetic Contactor, Manufactured with all UL listed & CSA approved electrical components.			
	Service Light (Standard)	25 Watt, Amber, 120 VAC			
<b>RECOVERY TANK</b>					
Item 10	Body Construction	304 Stainless Steel			
	Internal Screen	304 Stainless Steel			
	Filter Bag	25 Micron Polypropylene			
	Differential Press. Switch	Dial Indicator with N.O. Dry Contact			
<b>PURGE VALVE</b>					
Item 11	Actuator, Motorized	120 VAC 60Hz			
	Connection type	1" Female NPT, Ball Valve			
<b>SPECIFICATIONS</b>					
	Dim "A"	73"			
	Dim "B"	26-1/8"			
	Dim "C"	29-1/4"			
	Max. Inlet P.S.I.	100			
	Max. Operating P.S.I.	150			
	Max. Operating Temp.	100°F			
	Inlet	3" NPT	4" FLG	3" NPT	4" FLG
	Outlet (NPT Thread)	3"			
	Shipping Weight	719 Lbs			

Note: Dimensions are approximate and are for reference only. Dimensions subject to change without notice. Weights are approximate.  
 \* Optional or as required by temperature/pressure requirements---Carbon Steel, Rust Inhibitor Primer with Enamel finish