

GRISWOLD FILTRATION

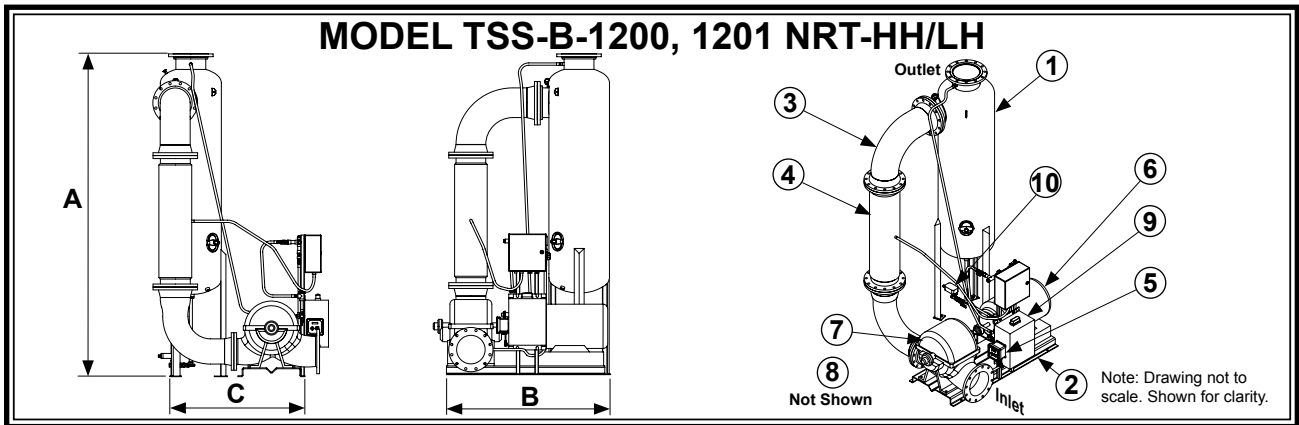

SYSTEM MODEL		TSS-B-1200-NRT-HH	TSS-B-1201-NRT-HH	TSS-B-1200-NRT-LH	TSS-B-1201-NRT-LH
Item 1	Design Flow Rate, GPM	2900@80 TDH *	3700@80 TDH	2900@40 TDH	3700@40 TDH
Item 1	Separator Model	CS-12T-FLG Carbon Steel, Powder Coated			
Item 2	Frame Construction	Carbon Steel, Powder Coated			
Item 3	Pipe Assembly	Carbon Steel, Rust Inhibitor Primer with Enamel finish			
Item 4	SBC Model	SBC-12000			
Item 5	Conductivity Meter	(SEE SECTION 12)			
MOTOR 460 VAC TEFC					
Item 6	Horsepower	75 hp	100 hp	40 hp	50 hp
Item 6	Approximate Amps @ 460V	96 amps	124 amps	52 amps	65 amps
	RPM	1750		1150	
PUMP					
Item 7	Pump Casing	Cast Iron			
Item 7	Pump Impeller	Bronze			
Item 7	Std. Mechanical Seal	VITON Elastomer, Silicon Carbide Seat, Carbon Rotary			
STRAINER (Standard)		Basket	Y-Strainer		
Item 8	Body Construction	Cast Iron			
Item 8	Internal Screen	1/4" Perforated 304 Stainless Steel			
Item 8	Connection Type	Class 150 FLG			
CONTROL PANEL (UL listed and labeled, manufactured to UL-508A Std.)					
Item 9	Enclosure	NEMA 4 Powder Coated, Watertight, UL listed and CSA approved			
Item 9	Electrical Components	Starter with Thermal Overload, HOA, 460/120 Transformer with Circuit Breakers, Pump "RUN" Light, Lockable Door Disconnect, Magnetic Contactor, Manufactured with all UL listed & CSA approved electrical components.			
Item 9	Service Light (Standard)	25 Watt, Amber, 120 VAC			
PURGE VALVE					
Item 10	Actuator, Motorized	120 VAC 60Hz			
Item 10	Connection type	2" Female NPT, Ball Valve			
SPECIFICATIONS					
Dim "A"	148"				
Dim "B"	70"	72"	70"	72"	
Dim "C"	84"	106"	84"	106"	
Max. Inlet P.S.I.	100				
Max. Operating P.S.I.	150				
Max. Operating Temp.	120°F				
Inlet (Class 150 FLG.)	10"	12"			
Outlet (Class 150 FLG.)	12"				
Shipping Weight	5400 Lbs	6000 Lbs	5400 Lbs	6000 Lbs	

Note: Dimensions are approximate and are for reference only. Dimensions subject to change without notice. Weights are approximate.
* Component Arrangement May Vary from Drawing