

GRISWOLD FILTRATION

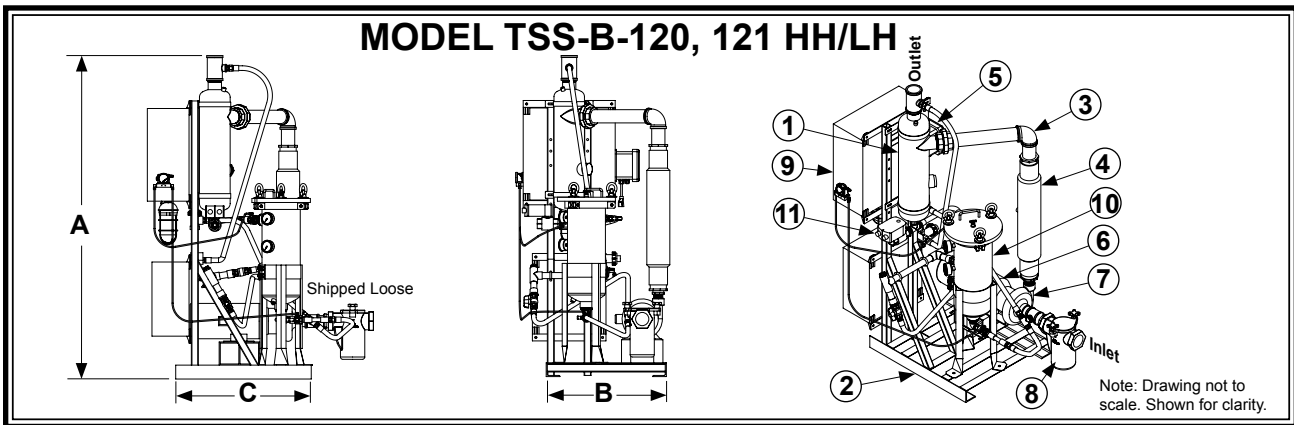

SYSTEM MODEL		TSS-B-120-HH	TSS-B-121-HH	TSS-B-120-LH	TSS-B-121-LH
	Design Flow Rate, GPM	40@80 TDH	50@80 TDH	40@40 TDH	50@40 TDH
Item 1	Separator Model	CS-1.2T-THD Carbon Steel, Powder Coated			
Item 2	Frame Construction	Carbon Steel, Powder Coated			
Item 3	Pipe Assembly	Schedule 80 PVC with Enamel Finish*			
Item 4	SBC Model	SBC-2000			
Item 5	Conductivity Meter	(SEE SECTION 12)			
MOTOR 460 VAC TEFC					
Item 6	Horsepower	2 hp		3/4 hp	1-1/2 hp
	Approximate Amps @ 460V	3.4 amps		1.6 amps	3 amps
	RPM	3500			
PUMP					
Item 7	Pump Casing	Cast Iron			
	Pump Impeller	Bronze			
	Std.Mechanical Seal	VITON Elastomer, Silicon Carbide Seat, Carbon Rotary			
BASKET STRAINER (Standard)					
Item 8	Body Construction	Cast Iron			
	Internal Screen	1/4" Perforated 304 Stainless Steel			
	Connection Type	Female NPT Thread			
CONTROL PANEL (UL listed and labeled, manufactured to UL-508A Std.)					
Item 9	Enclosure	NEMA 4 Powder Coated, Watertight, UL listed and CSA approved			
	Electrical Components	Starter with Thermal Overload, HOA, 460/120 Transformer with Circuit Breakers, Pump "RUN" Light, Lockable Door Disconnect, Magnetic Contactor, Manufactured with all UL listed & CSA approved electrical components.			
	Service Light (Standard)	25 Watt, Amber, 120 VAC			
RECOVERY TANK					
Item 10	Body Construction	304 Stainless Steel			
	Internal Screen	304 Stainless Steel			
	Filter Bag	25 Micron Polypropylene			
	Differential Press. Switch	Dial Indicator with N.O. Dry Contact			
PURGE VALVE					
Item 11	Actuator, Motorized	120 VAC 60Hz			
	Connection type	1" Female NPT, Ball Valve			
SPECIFICATIONS					
	Dim "A"	67"			
	Dim "B"	26-1/8"			
	Dim "C"	29-1/4"			
	Max. Inlet P.S.I.	100			
	Max. Operating P.S.I.	150			
	Max. Operating Temp.	100°F			
	Inlet (NPT Thread)	1-1/2"		2-1/2"	
	Outlet (NPT Thread)	1-1/4"			
	Shipping Weight	459 Lbs			

Note: Dimensions are approximate and are for reference only. Dimensions subject to change without notice. Weights are approximate.
 * Optional or as required by temperature/pressure requirements---Carbon Steel, Rust Inhibitor Primer with Enamel finish