

GRISWOLD FILTRATION

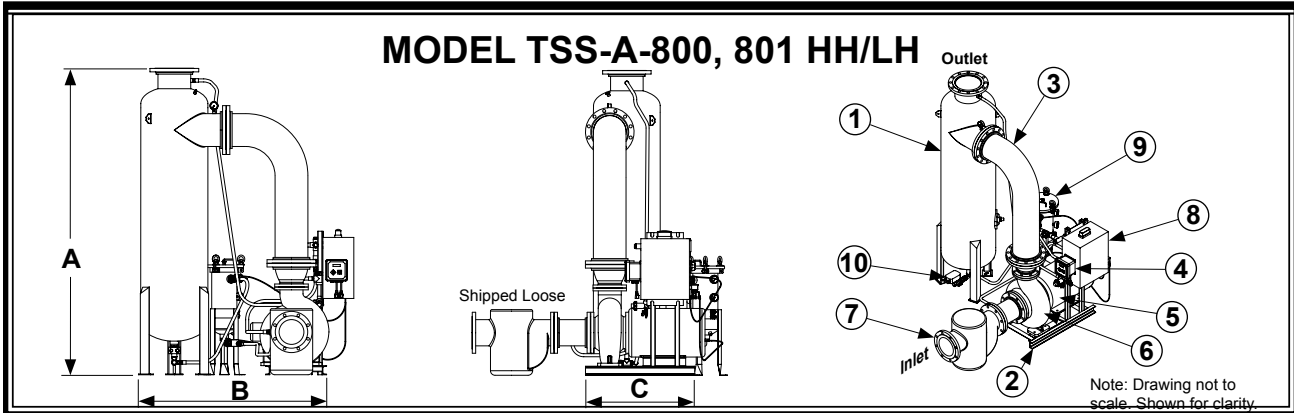

SYSTEM MODEL		TSS-A-800-HH	TSS-A-801-HH	TSS-A-800-LH	TSS-A-801-LH
	Design Flow Rate, GPM	1400@80 TDH	1700@80 TDH	1400@40 TDH	1700@40 TDH
Item 1	Separator Model	CS-8T-FLG Carbon Steel, Powder Coated			
Item 2	Frame Construction	Carbon Steel, Powder Coated			
Item 3	Pipe Assembly	Carbon Steel, Rust Inhibitor Primer with Enamel finish			
Item 4	Conductivity Meter	(SEE SECTION 12)			
MOTOR 460 VAC TEFC					
Item 5	Horsepower	40 hp	50 hp	20 hp	25 hp
	Approximate Amps @ 460V	52 amps	65 amps	27 amps	34 amps
	RPM	1750			
PUMP					
Item 6	Pump Casing	Cast Iron			
	Pump Impeller	Bronze			
	Std.Mechanical Seal	VITON Elastomer, Silicon Carbide Seat, Carbon Rotary			
BASKET STRAINER (Standard)					
Item 7	Body Construction	Cast Iron			
	Internal Screen	1/4" Perforated 304 Stainless Steel			
	Connection Type	Class 150 FLG.			
CONTROL PANEL (UL listed and labeled, manufactured to UL-508A Std.)					
Item 8	Enclosure	NEMA 4 Powder Coated, Watertight, UL listed and CSA approved			
	Electrical Components	Starter with Thermal Overload, HOA, 460/120 Transformer with Circuit Breakers, Pump "RUN" Light, Lockable Door Disconnect, Magnetic Contactor, Manufactured with all UL listed & CSA approved electrical components.			
	Service Light (Std.)	25 Watt, Amber, 120 VAC			
RECOVERY TANK					
Item 9	Body Construction	304 Stainless Steel			
	Internal Screen	304 Stainless Steel			
	Filter Bag	25 Micron Polypropylene			
	Differential Press. Switch	Dial Indicator with Dry N.O. Contact			
PURGE VALVE					
Item 10	Actuator, Motorized Spring Return	120 VAC 60Hz			
	Connection type	2" Female NPT, Ball Valve			
SPECIFICATIONS					
	Dim "A"	88"			
	Dim "B"	60"			
	Dim "C"	50"			
	Max. Inlet P.S.I.	100			
	Max. Operating P.S.I.	150			
	Max. Operating Temp.	120°F			
	Inlet (Class 150 FLG.)	8"			
	Outlet (Class 150 FLG.)	8"			
	Shipping Weight	2800 Lbs		1850 Lbs	

Note: Dimensions are approximate and are for reference only. Dimensions subject to change without notice. Weights are approximate.