

GRISWOLD FILTRATION

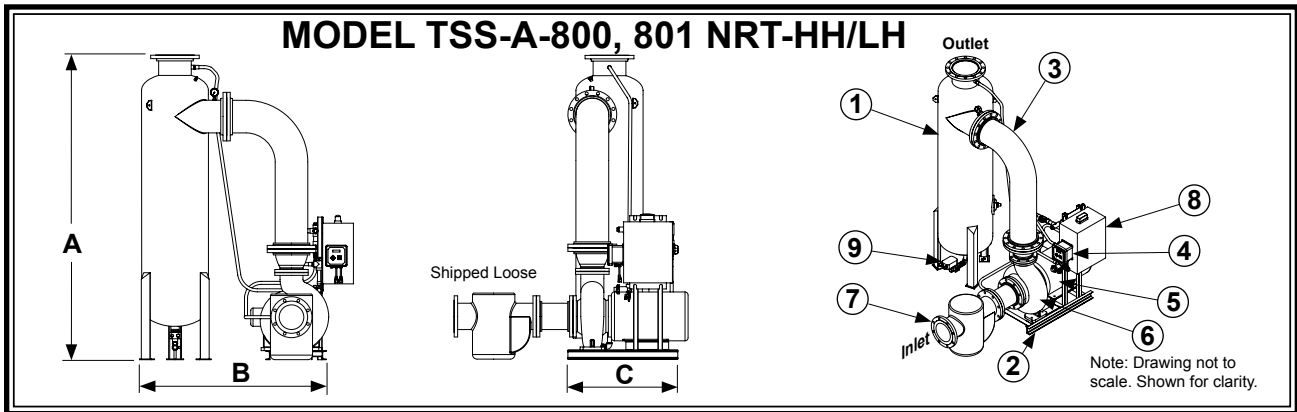

SYSTEM MODEL		TSS-A-800-NRT-HH	TSS-A-801-NRT-HH	TSS-A-800-NRT-LH	TSS-A-801-NRT-LH
	Design Flow Rate, GPM	1400@80 TDH	1700@80 TDH	1400@40 TDH	1700@40 TDH
Item 1	Separator Model	CS-8T-FLG Carbon Steel, Powder Coated			
Item 2	Frame Construction	Carbon Steel, Powder Coated			
Item 3	Pipe Assembly	Carbon Steel, Rust Inhibitor Primer with Enamel finish			
Item 4	Conductivity Meter	(SEE SECTION 12)			
MOTOR 460 VAC TEFC					
	Horsepower	40 hp	50 hp	20 hp	25 hp
Item 5	Approximate Amps @ 460V	52 amps	65 amps	27 amps	34 amps
	RPM	1750			
PUMP					
	Pump Casing	Cast Iron			
Item 6	Pump Impeller	Bronze			
	Std. Mechanical Seal	VITON Elastomer, Silicon Carbide Seat, Carbon Rotary			
BASKET STRAINER (Standard)					
	Body Construction	Cast Iron			
Item 7	Internal Screen	1/4" Perforated 304 Stainless Steel			
	Connection Type	Class 150 FLG.			
CONTROL PANEL (UL listed and labeled, manufactured to UL-508A Std.)					
	Enclosure	NEMA 4 Powder Coated, Watertight, UL listed and CSA approved			
Item 8	Electrical Components	Starter with Thermal Overload, HOA, 460/120 Transformer with Circuit Breakers, Pump "RUN" Light, Lockable Door Disconnect, Magnetic Contactor, Manufactured with all UL listed & CSA approved electrical components.			
	Service Light (Std.)	25 Watt, Amber, 120 VAC			
PURGE VALVE					
Item 9	Actuator, Motorized Spring Return	120 VAC 60Hz			
	Connection type	2" Female NPT, Ball Valve			
SPECIFICATIONS					
	Dim "A"			88"	
	Dim "B"			60"	
	Dim "C"			50"	
	Max. Inlet P.S.I.			100	
	Max. Operating P.S.I.			150	
	Max. Operating Temp.			120°F	
	Inlet (Class 150 FLG.)			8"	
	Outlet (Class 150 FLG.)			8"	
	Shipping Weight	2800 Lbs		1850 Lbs	

Note: Dimensions are approximate and are for reference only. Dimensions subject to change without notice. Weights are approximate.