

# GRISWOLD FILTRATION

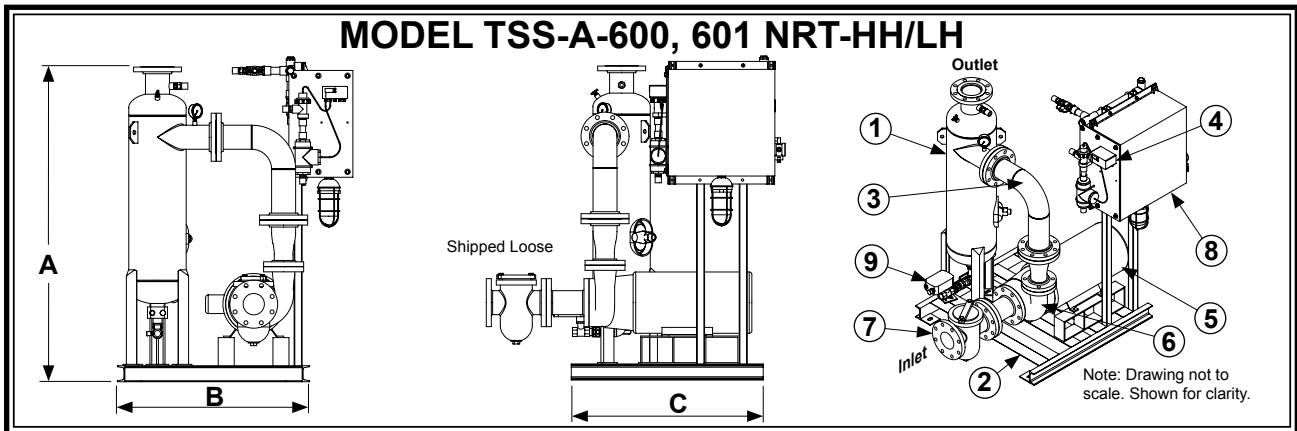

SYSTEM MODEL		TSS-A-600-NRT-HH	TSS-A-601-NRT-HH	TSS-A-600-NRT-LH	TSS-A-601-NRT-LH
	Design Flow Rate, GPM	810@80 TDH	1100@80 TDH	810@40 TDH	1100@40 TDH
Item 1	Separator Model	CS-6T-FLG Carbon Steel, Powder Coated			
Item 2	Frame Construction	Carbon Steel, Powder Coated			
Item 3	Pipe Assembly	Schedule 80 PVC with Enamel Finish*			
Item 4	Conductivity Meter	(SEE SECTION 12)			
<b>MOTOR 460 VAC TEFC</b>					
Item 5	Horsepower	20 hp	30 hp	15 hp	20 hp
	Approximate Amps @ 460V	27 amps	40 amps	21 amps	27 amps
	RPM	1750		3500	1750
<b>PUMP</b>					
Item 6	Pump Casing	Cast Iron			
	Pump Impeller	Bronze			
	Std.Mechanical Seal	VITON Elastomer, Silicon Carbide Seat, Carbon Rotary			
<b>BASKET STRAINER (Standard)</b>					
Item 7	Body Construction	Cast Iron			
	Internal Screen	1/4" Perforated 304 Stainless Steel			
	Connection Type	Class 150 FLG			
<b>CONTROL PANEL (UL listed and labeled, manufactured to UL-508A Std.)</b>					
Item 8	Enclosure	NEMA 4 Powder Coated, Watertight, UL listed and CSA approved			
	Electrical Components	Starter with Thermal Overload, HOA, 460/120 Transformer with Circuit Breakers, Pump "RUN" Light, Lockable Door Disconnect, Magnetic Contactor, Timer, Manufactured with all UL listed & CSA approved electrical components.			
	Service Light (Std.)	25 Watt, Amber, 120 VAC			
<b>PURGE VALVE</b>					
Item 9	Actuator, Motorized Spring Return	120 VAC 60Hz			
	Connection type	1-1/2" Female NPT, Ball Valve			
<b>SPECIFICATIONS</b>					
	Dim "A"	76"			
	Dim "B"	42"			
	Dim "C"	42"			
	Max. Inlet P.S.I.	100			
	Max. Operating P.S.I.	150			
	Max. Operating Temp.	100°F			
	Inlet (Class 150 FLG.)	6"		5"	8"
	Outlet (Class 150 FLG.)	6"			
	Shipping Weight	1500 Lbs		1300 Lbs	

Note: Dimensions are approximate and are for reference only. Dimensions subject to change without notice. Weights are approximate.  
 \* Optional or as required by temperature/pressure requirements---Carbon Steel, Rust Inhibitor Primer with Enamel finish.

**SECTION 8**