

GRISWOLD FILTRATION

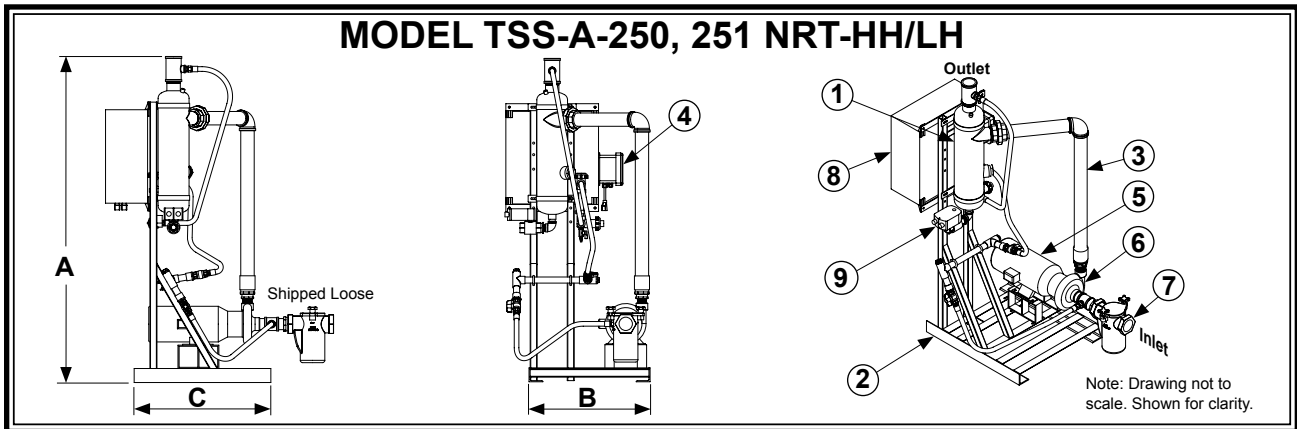

SYSTEM MODEL		TSS-A-250-NRT-HH	TSS-A-251-NRT-HH	TSS-A-250-NRT-LH	TSS-A-251-NRT-LH
	Design Flow Rate, GPM	130@80 TDH	160@80 TDH	130@40 TDH	160@40 TDH
Item 1	Separator Model	CS-2.5T-THD Carbon Steel, Powder Coated			
Item 2	Frame Construction	Carbon Steel, Powder Coated			
Item 3	Pipe Assembly	Schedule 80 PVC with Enamel Finish*			
Item 4	Conductivity Meter	(SEE SECTION 12)			
MOTOR 460 VAC TEFC					
Item 5	Horsepower	5 hp		3 hp	
	Approximate Amps @ 460V	7.6 amps		4.8 amps	
	RPM	3500			
PUMP					
Item 6	Pump Casing	Cast Iron			
	Pump Impeller	Bronze			
	Std.Mechanical Seal	VITON Elastomer, Silicon Carbide Seat, Carbon Rotary			
BASKET STRAINER (Standard)					
Item 7	Body Construction	Cast Iron			
	Internal Screen	1/4" Perforated 304 Stainless Steel			
	Connection Type	Female NPT Thread		Class 150 FLG	
CONTROL PANEL (UL listed and labeled, manufactured to UL-508A Std.)					
Item 8	Enclosure	NEMA 4 Powder Coated, Watertight, UL listed and CSA approved			
	Electrical Components	Starter with Thermal Overload, HOA, 460/120 Transformer with Circuit Breakers, Pump "RUN" Light, Lockable Door Disconnect, Magnetic Contactor, Timer, Manufactured with all UL listed & CSA approved electrical components.			
	Service Light (Std.)	25 Watt, Amber, 120 VAC			
PURGE VALVE					
Item 9	Actuator, Motorized Spring Return	120 VAC 60Hz			
	Connection type	1" Female NPT, Ball Valve			
SPECIFICATIONS					
Dim "A"		67"			
Dim "B"		26-1/8"			
Dim "C"		29-1/4"			
Max. Inlet P.S.I.		100			
Max. Operating P.S.I.		150			
Max. Operating Temp.		100°F			
Inlet		2-1/2" NPT Thread		4" FLG	
Outlet (NPT Thread)		2-1/2"			
Shipping Weight		550 Lbs		470 Lbs	

Note: Dimensions are approximate and are for reference only. Dimensions subject to change without notice. Weights are approximate.
 * Optional or as required by temperature/pressure requirements---Carbon Steel, Rust Inhibitor Primer with Enamel finish.