

GRISWOLD FILTRATION

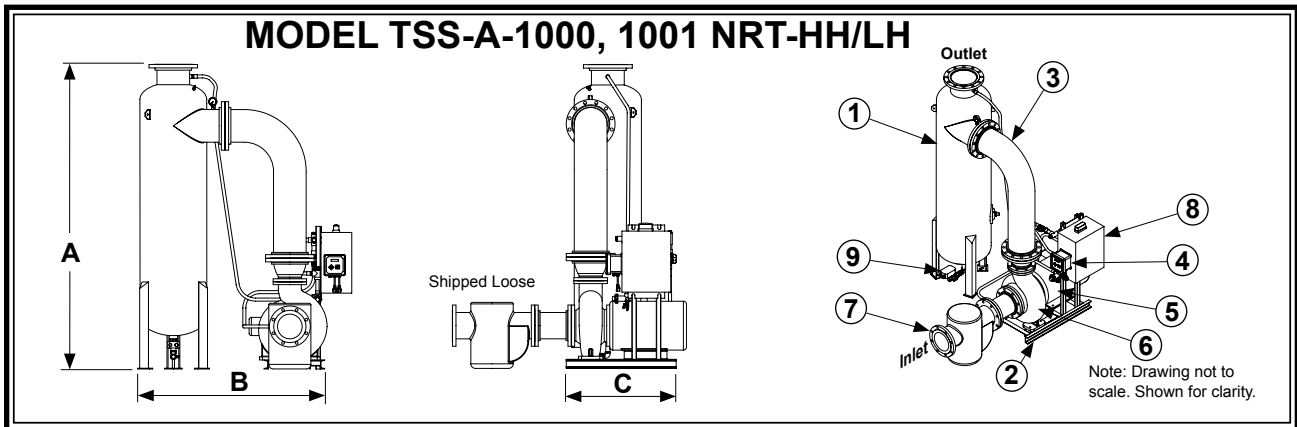

SYSTEM MODEL		TSS-A-1000-NRT-HH	TSS-A-1001-NRT-HH	TSS-A-1000-NRT-LH	TSS-A-1001-NRT-LH
	Design Flow Rate, GPM	2000@80 TDH	2700@80 TDH	2000@40 TDH	2700@40 TDH
Item 1	Separator Model	CS-10T-FLG Carbon Steel, Powder Coated			
Item 2	Frame Construction	Carbon Steel, Powder Coated			
Item 3	Pipe Assembly	Carbon Steel, Rust Inhibitor Primer with Enamel finish			
Item 4	Conductivity Meter	(SEE SECTION 12)			
MOTOR 460 VAC TEFC					
Item 5	Horsepower	50 hp	75 hp	25 hp	40 hp
	Approximate Amps @ 460V	65 amps	96 amps	24 amps	52 amps
	RPM	1750		1150	
PUMP					
Item 6	Pump Casing	Cast Iron			
	Pump Impeller	Bronze			
	Std. Mechanical Seal	VITON Elastomer, Silicon Carbide Seat, Carbon Rotary			
BASKET STRAINER (Standard)					
Item 7	Body Construction	Cast Iron			
	Internal Screen	1/4" Perforated 304 Stainless Steel			
	Connection Type	Class 150 FLG.			
CONTROL PANEL (UL listed and labeled, manufactured to UL-508A Std.)					
Item 8	Enclosure	NEMA 4 Powder Coated, Watertight, UL listed and CSA approved			
	Electrical Components	Starter with Thermal Overload, HOA, 460/120 Transformer with Circuit Breakers, Pump "RUN" Light, Lockable Door Disconnect, Magnetic Contactor, Manufactured with all UL listed & CSA approved electrical components.			
	Service Light (Std.)	25 Watt, Amber, 120 VAC			
PURGE VALVE					
Item 9	Actuator, Motorized Spring Return	120 VAC 60Hz			
	Connection type	2" Female NPT, Ball Valve			
SPECIFICATIONS					
Dim "A"		103"			
Dim "B"		68"			
Dim "C"		45"			
Max. Inlet P.S.I.		100			
Max. Operating P.S.I.		150			
Max. Operating Temp.		120°F			
Inlet (Class 150 FLG.)		8"	10"	12"	
Outlet (Class 150 FLG.)		10"			
Shipping Weight		3800 Lbs		3200 Lbs	4200 Lbs

Note: Dimensions are approximate and are for reference only. Dimensions subject to change without notice. Weights are approximate.