

GRISWOLD FILTRATION

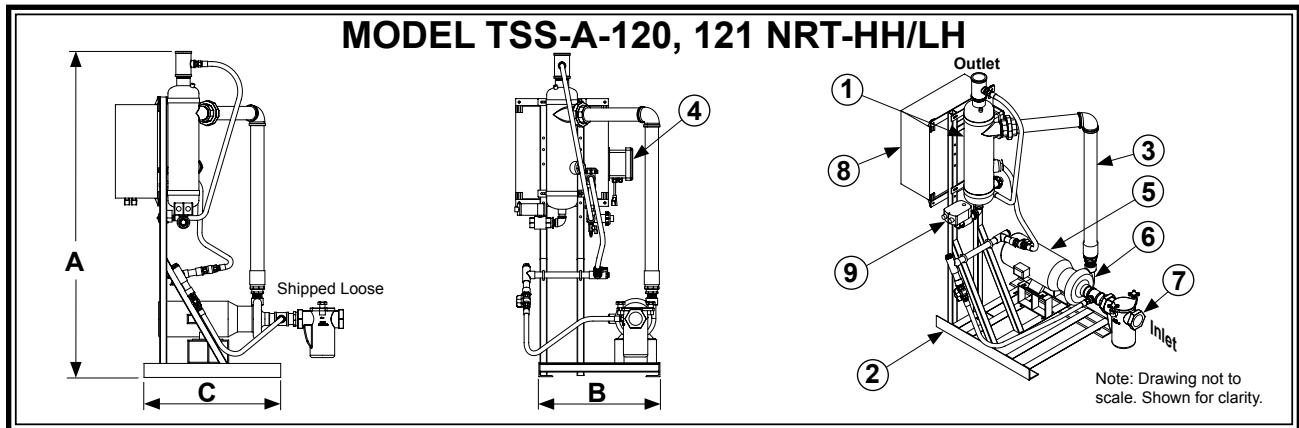

SYSTEM MODEL		TSS-A-120-NRT-HH	TSS-A-121-NRT-HH	TSS-A-120-NRT-LH	TSS-A-121-NRT-LH
	Design Flow Rate, GPM	40@80 TDH	50@80 TDH	40@40 TDH	50@40 TDH
Item 1	Separator Model	CS-1.2T-THD Carbon Steel, Powder Coated			
Item 2	Frame Construction	Carbon Steel, Powder Coated			
Item 3	Pipe Assembly	Schedule 80 PVC with Enamel Finish*			
Item 4	Conductivity Meter	(SEE SECTION 12)			
MOTOR 460 VAC TEFC					
Item 5	Horsepower	2 hp		3/4 hp	1-1/2 hp
	Approximate Amps @ 460V	3.4 amps		1.6 amps	3 amps
	RPM	3500			
PUMP					
Item 6	Pump Casing	Cast Iron			
	Pump Impeller	Bronze			
	Std.Mechanical Seal	VITON Elastomer, Silicon Carbide Seat, Carbon Rotary			
BASKET STRAINER (Standard)					
Item 7	Body Construction	Cast Iron			
	Internal Screen	1/4" Perforated 304 Stainless Steel			
	Connection Type	Female NPT Thread			
CONTROL PANEL (UL listed and labeled, manufactured to UL-508A Std.)					
Item 8	Enclosure	NEMA 4 Powder Coated, Watertight, UL listed and CSA approved			
	Electrical Components	Starter with Thermal Overload, HOA, 460/120 Transformer with Circuit Breakers, Pump "RUN" Light, Lockable Door Disconnect, Magnetic Contactor, Timer, Manufactured with all UL listed & CSA approved electrical components.			
	Service Light (Std.)	25 Watt, Amber, 120 VAC			
PURGE VALVE					
Item 9	Actuator, Motorized Spring Return	120 VAC 60Hz			
	Connection type	1" Female NPT, Ball Valve			
SPECIFICATIONS					
	Dim "A"	67"			
	Dim "B"	26-1/8"			
	Dim "C"	29-1/4"			
	Max. Inlet P.S.I.	100			
	Max. Operating P.S.I.	150			
	Max. Operating Temp.	100°F			
	Inlet (NPT Thread)	1-1/2"		2-1/2"	
	Outlet (NPT Thread)	1-1/4"			
	Shipping Weight	400 Lbs		360 Lbs	

Note: Dimensions are approximate and are for reference only. Dimensions subject to change without notice. Weights are approximate.
 * Optional or as required by temperature/pressure requirements---Carbon Steel, Rust Inhibitor Primer with Enamel finish.

SECTION 8